

Product Platform "MOBILE"

Setting your concept in motion



About Bucher Hydraulics Mobile Drives

Mobile Drives is a department of Bucher Hydraulics that develops and supplies frequency converters, DC/DC converters and drive technology for mobile applications.

Since 2021, the department has been part of Bucher Hydraulics, which designs and manufactures electrohydraulic system solutions and hydraulic components. The Bucher Hydraulics division is part of the Bucher Industries group.

Innovation with a global network

We are focused on the development of technology that is energy-efficient and therefore causes less harm to the environment – an extremely creative activity that requires a flair for experimentation with and investigation of new technologies. With several globally distributed competence centers and production sites, Bucher Hydraulics is a dynamic player in the global market from whose know-how you as a customer benefit directly.

What drives us

Our engineers work on innovative drive solutions that are ready for use and available today while also providing longterm perspectives for future development cycles. Creativity and openness to new technologies form the basis for adapting to basic conditions, which are changing faster than ever.

What we offer

- Off the shelf product platform MOBILE containing solutions for the electrification of auxiliary drives in commercial vehicles
- Case and system studies as well as concepts for individual customized applications



Bucher Hydraulics Mobile Drives in Romanshorn, Switzerland

Bucher Hydraulics worldwide locations

- Germany:
Klettgau, Erding,
Remscheid, Dachau
- Switzerland: Frutigen,
Neuheim, Romanshorn
- Italy: Reggio Emilia
- USA: Grand Rapids, Elgin
- China: Wuxi, Suzhou
- India: Gurgaon
- Brazil: Canoas

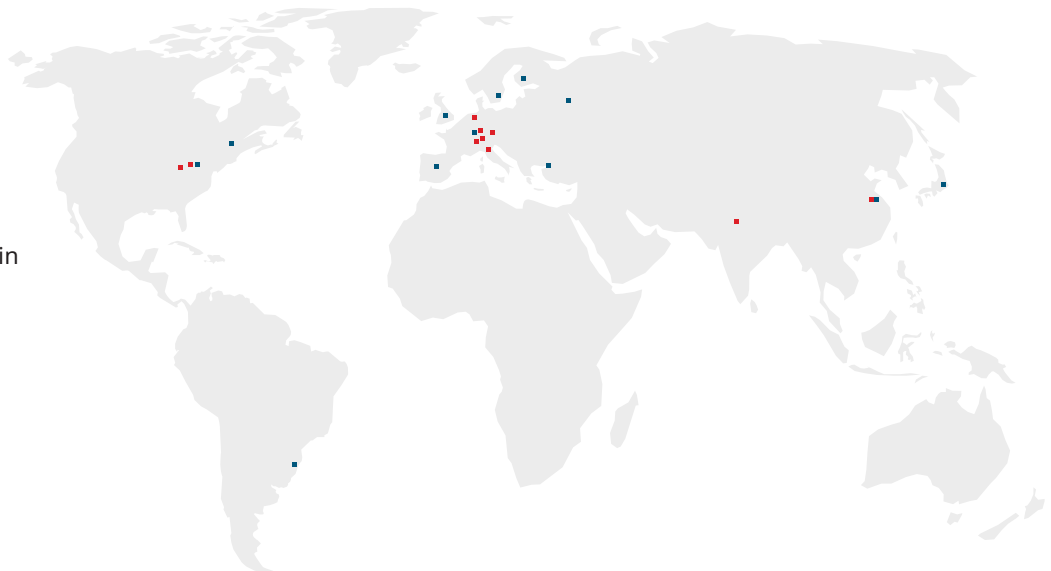

- Bucher Hydraulics
Competence Center
- Bucher Hydraulics
Sales Center

Together, We Are the Force Behind the Markets of Tomorrow

The use of electric drives opens up an increasing number of possibilities for your forward-looking, green and economical vehicle concepts.

Leading the way in mobile drives, we develop innovative, reliable, and economical solutions for electric and hybrid vehicles: from the concept to consulting and guidance in the prototype project as well as production. The experience and know-how of our engineers and network of experts,

who are showing the way forward in the area of mobile applications, are poured into all the work they do – from the concept stage to production. This ensures innovative, reliable and economically efficient solutions for both electric and hybrid drives.





What sets us apart on the market

In addition to our many years of development experience and comprehensive engineering competence, we have the expertise, capacities, and reliable procurement that are required for the large-scale production of performance electronics.

One approach – two advantages

This has resulted in a modular drive system based on a catalog approach, which, on the one hand, minimizes the

effort and time required for implementation in a vehicle concept. This enables you to implement your projects more quickly. On the other hand, this approach fulfills a key requirement with regard to the product life cycle – the reliable availability of components. Our modular system is designed to fit into your vehicle concept in terms of form and function over a long period of time. The catalog approach also underlies our procurement processes, thus creating long-term reliability.

The full package is what makes the difference and ensures success



MOBILE Product Platform

For electrical units in commercial vehicles

Consistent development

The compact MOBILE product platform with multi-inverters and DC/DC converters – for successful integration into your commercial vehicles. When looking for the right products to suit your requirements, you have the option of choosing from our MOBILE modular drive system for applications in commercial vehicles.

Catalog-based modular drive systems

The catalog approach makes it easy to find the right type for your application. Furthermore, its scalability covers a wide power range with identical overall external dimensions.

Whether you are a vehicle manufacturer or a supplier, you can configure and implement optimally tailored drive solutions for the respective task both quickly and with ease.

Together, we will select the appropriate solution for your application. Integration into the vehicle then takes place with the aid of a uniform concept for the connection system.

Designed specifically for use in commercial vehicles in rough environments:

- City buses
- Trucks
- Mobile working machines such as
 - Construction vehicles
 - Mining vehicles
- Agricultural vehicles such as
 - Tractors
 - Various implements
 - Mowers

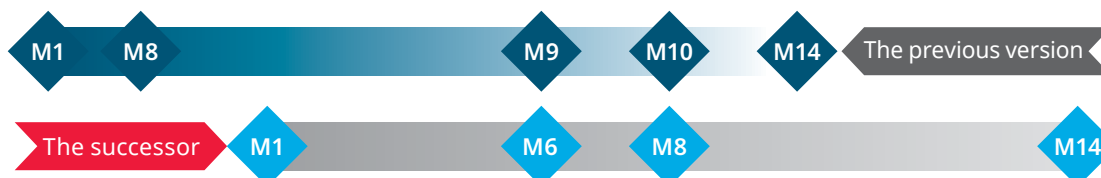

Performance, safety, and reliability over the entire product life cycle

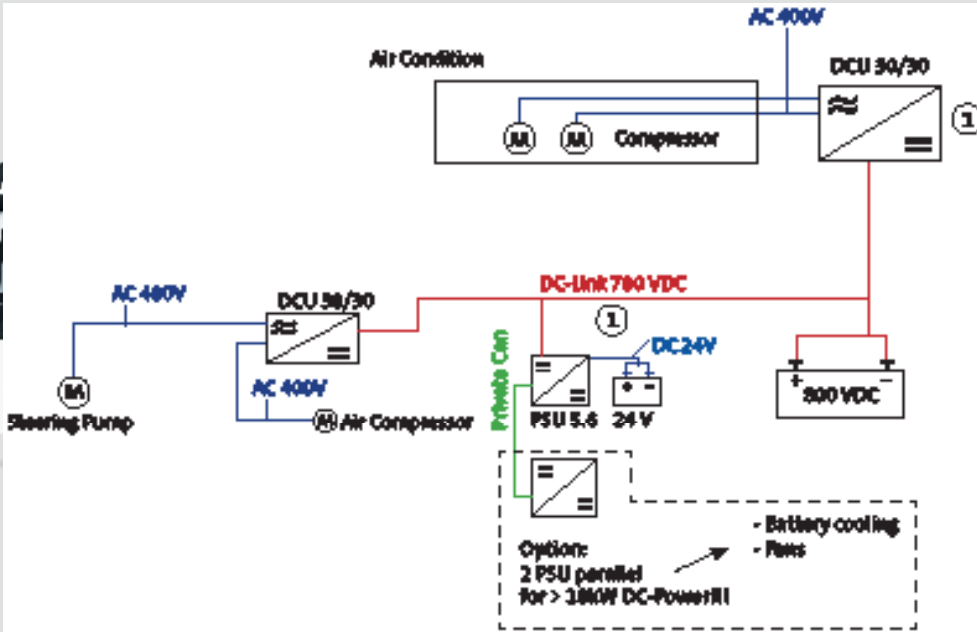

Typical auxiliary drives in a city bus – smart electrified with the MOBILE platform

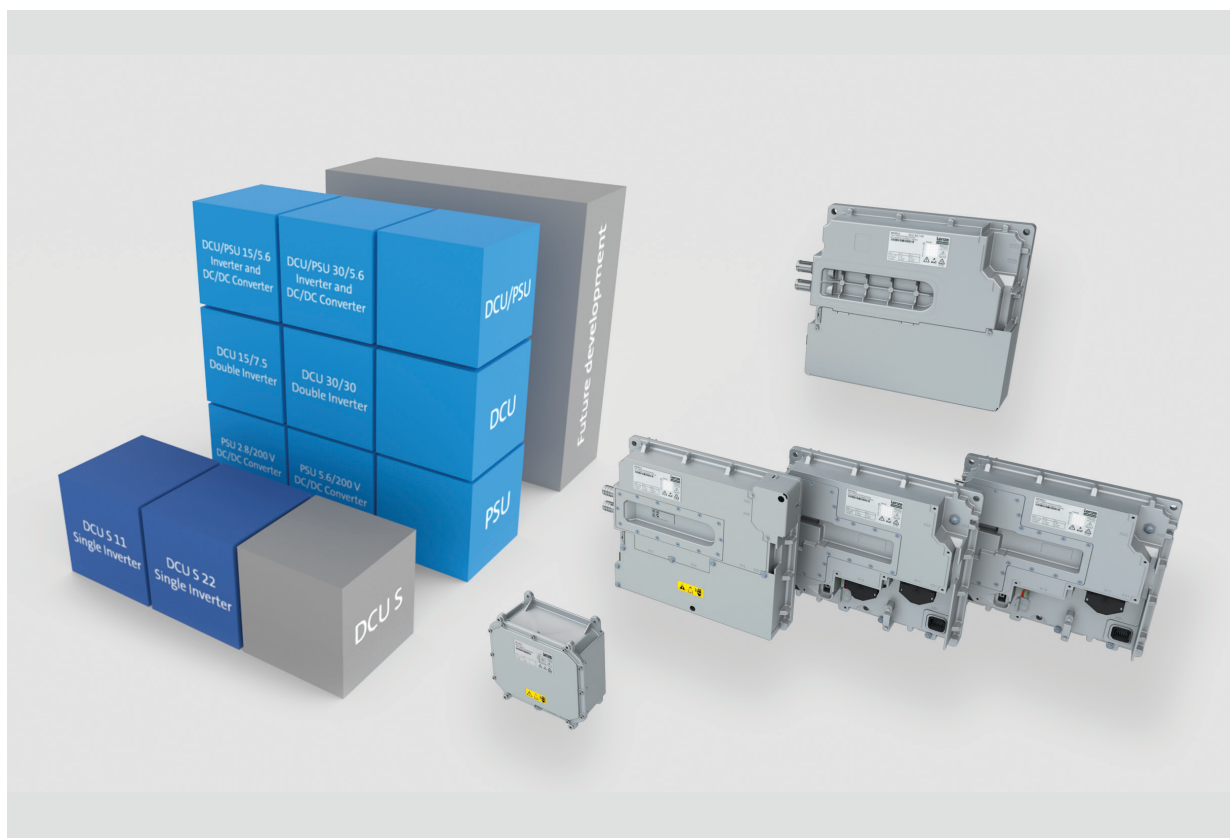

MOBILE platform: ready to solve different applications

Implement Your Individual Drive Solution Fast and Easy

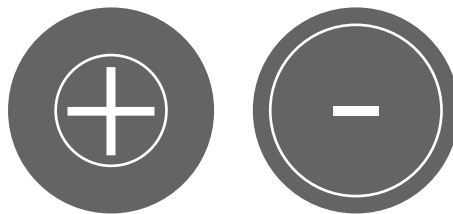

Increase Reduce

- | | |
|---------------------|-------------------------|
| Energy efficiency | Development expenditure |
| System integration | Process complexity |
| Customization | Risk potential |
| Series availability | Product launch time |

Designed specifically for use in commercial vehicles in rough environments:

- Ready-to-use modular system
- Device versions and outputs can be chosen to suit your requirements
- Adjustment begins at a high development level

Designed specifically for applications in commercial vehicles:

- Service life and designed for applications in commercial vehicles exposed to rough environments

Easy integration into your system:

- Each model variant comes with the same external dimensions and interfaces
- Extremely easy to integrate into the vehicle system via a standard communication bus

Wide range of versions available starting from series production:

- Large-scale production
- E1-qualified and -certified

Base housing concept for the entire modular system:

- Uniformly fulfills mechanical requirements
- Features plug connections

Short product launch times:

- Minimal development effort
- Low process complexity thanks to tried-and-tested series-produced components

Always the right solutions

For typical applications in commercial vehicles – even in rough environments

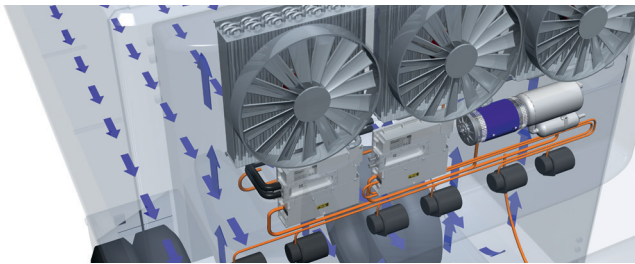

Control of drives for compressors and fans

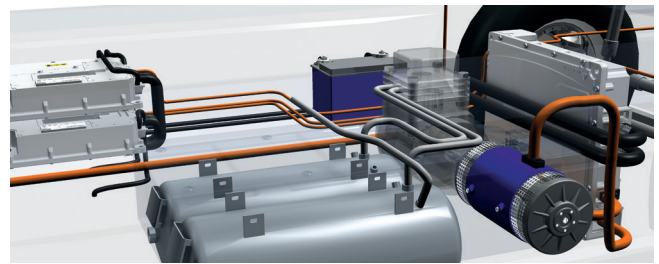

Control of drives for air compressors

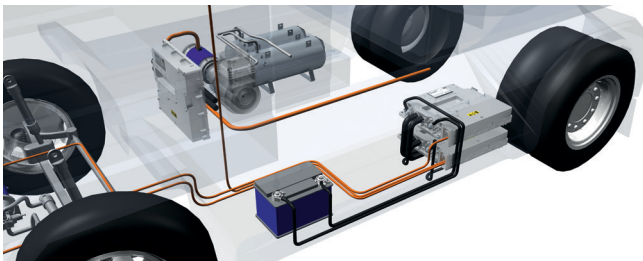

Provision of on-board supply system 12/24 VDC

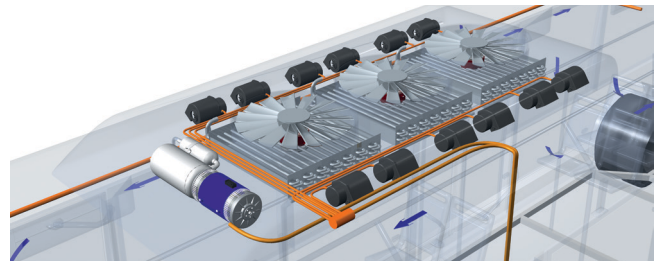

HVAC with CAN communication or digital I/Os

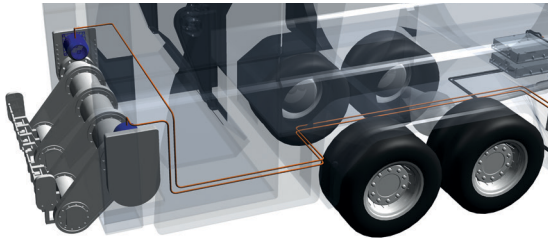

Positioning tasks for hoisting devices

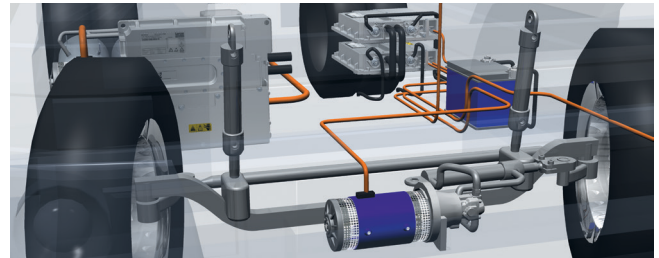

Control of drives for power steering pumps



Active front end control for power socket function

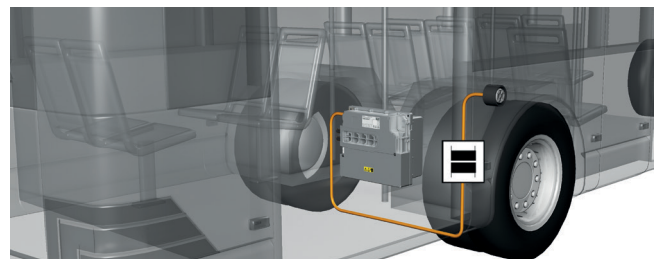

Active front end control for on-board charger

Establishing Efficient Networks: Communication

Our offer for vehicle communication helps you to easily integrate the solution into the vehicle system via a standard communication bus.

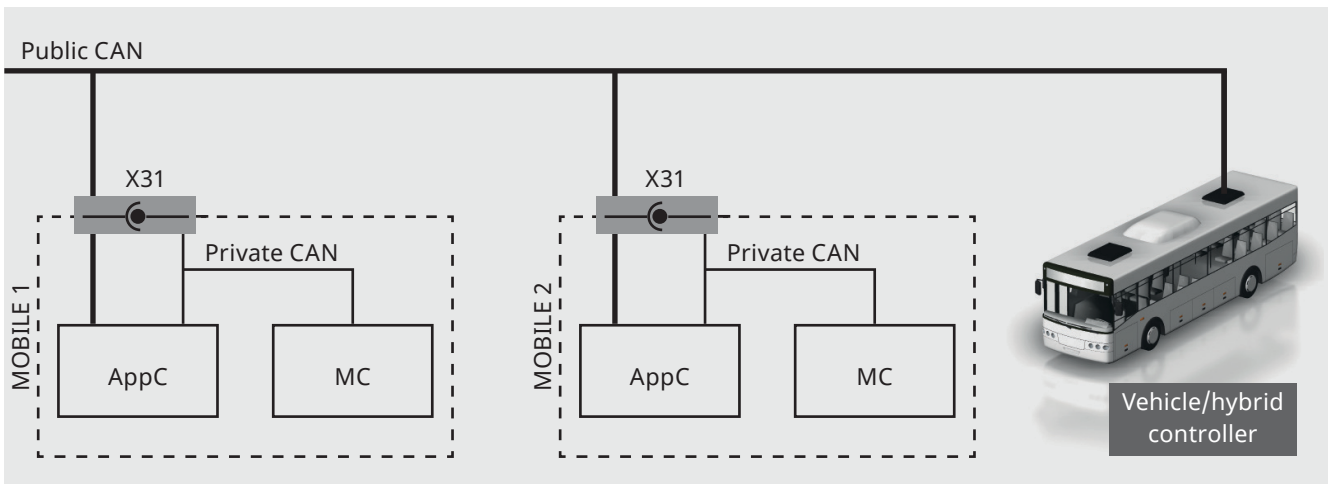

Communication between vehicle and MOBILE devices:

Equipped with two independent CAN buses:
PrivateCAN

PrivateCAN parameterization and communication between multiple interconnected devices – CANopen

PublicCAN

PublicCAN communication with the primary vehicle control system – CANbus J1939

The MOBILE devices have two different micro controllers:

Application Controller (AppC)

AppC takes care of controlling and integrating the auxiliary equipment into the vehicle and provides powerful diagnostics in accordance with UDS (Unified Diagnostic Services).

Motor Controller (MC)

The two motors or the DC/DC converter are controlled by a powerful digital signal processor (DSP) that has been optimized for real-time control.

Complete access at any time: Parameterization

Our tools for parameterization and diagnostics provide you with full access to the devices at all times. The MOBILE tools make commissioning easier for you, optimize energy management, and facilitate trouble-

shooting and debugging if there are any technical issues. Choose the right parameterization tool to suit your needs – and make your engineering simple and efficient in the process.

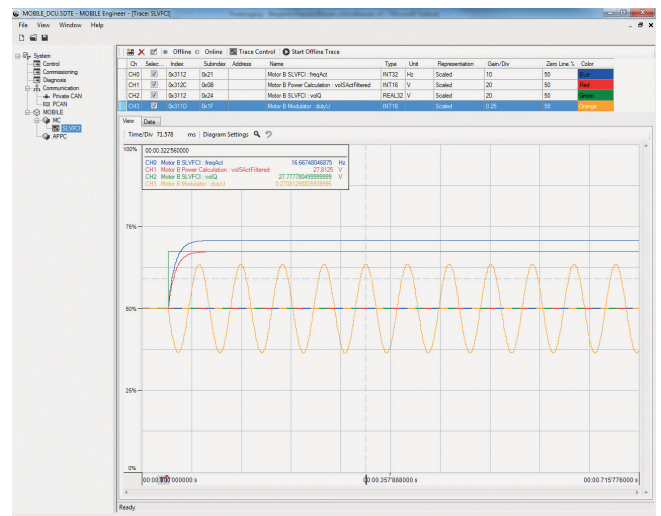
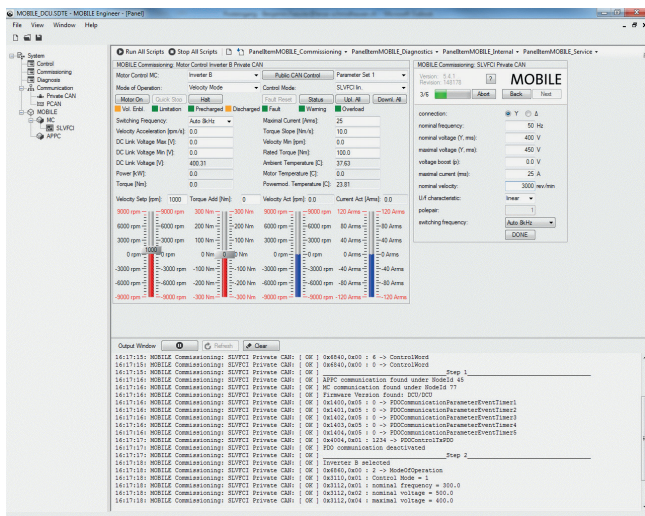

MOBILE Starter

Tool for service technicians quick and easy commissioning and maintenance:

- Load parameters
- Extremely easy access to the
- Device ID
- Device identification (request Type designation + parameters)
- Communication test (CAN)



MOBILE Engineer

Your comprehensive engineering software for Parameterization and configuration:

- Full access to parameterization
- Fine-tuning from MOBILE to the motor/consumer to be driven
- Detailed diagnostics
- Retrieval of device performance in real-time
- Visualization of measurement, such as process values over time
- Individually tailored masks

Your MOBILE Modular Systems at a Glance

Hardware Revision 000



Housing platform

Type	Operating voltage	DCU/PSU current peak ¹	Secondary DC voltage	DCU/PSU output current nominal	DCU/PSU output current peak ²	Type number	
DCU/PSU	30/5.6	200 ... 400 VDC	30 kW/5.6 kW	24 VDC	1 x 58 A/200 A	1 x 104 A/200 A	EMDAG4562303S00000
	30/2.8	200 ... 400 VDC	30 kW/2.8 kW	12 VDC	1 x 58 A/200 A	1 x 104 A/200 A	EMDAG4282303P00000
	15/5.6	200 ... 400 VDC	15 kW/5.6 kW	24 VDC	1 x 32 A/200 A	1 x 57 A/200 A	EMDAG4562153S00000
	15/2.8	200 ... 400 VDC	15 kW/2.8 kW	12 VDC	1 x 32 A/200 A	1 x 57 A/200 A	EMDAG4282153P00000
PSU	5.6	200 ... 400 VDC	5.6 kW	24 VDC	-/200 A	-/200 A	EMDAG3562000S00000
	2.8	200 ... 400 VDC	2.8 kW	12 VDC	-/200 A	-/200 A	EMDAG3282000P00000

Hardware Revision 010

Type	Operating voltage	DCU/PSU current peak ¹	Secondary DC voltage	DCU/PSU output current nominal	DCU/PSU output current peak ²	Type number	
DCU	60/60	200 ... 848 VDC	2 x 60 kW	-	2 x 58 A	2 x 104 A	EMDAG2603603U00010
	30/30	200 ... 848 VDC	2 x 30 kW	-	2 x 32 A	2 x 57 A	EMDAG2303303U00010
	30/15	200 ... 848 VDC	1 x 30 kW 1 x 15 kW	-	1 x 32 A 1 x 15 A	1 x 57 A 1 x 27 A	EMDAG2303153U00010
	15/7.5	200 ... 848 VDC	1 x 15 kW 1 x 7.5 kW	-	1 x 15 A 1 x 8 A	1 x 27 A 1 x 14 A	EMDAG2153752U00010
DCU/PSU	60/5.6	360 ... 848 VDC	60 kW/5.6 kW	24 VDC	1 x 58 A/200 A	1 x 104 A/200 A	EMDAG4562603C00010
	60/2.8	360 ... 848 VDC	60 kW/2.8 kW	12 VDC	1 x 58 A/200 A	1 x 104 A/200 A	EMDAG4282603T00010
	30/5.6	360 ... 848 VDC	30 kW/5.6 kW	24 VDC	1 x 32 A/200 A	1 x 57 A/200 A	EMDAG4562303C00010
	30/2.8	200 ... 848 VDC	30 kW/2.8 kW	12 VDC	1 x 32 A/200 A	1 x 57 A/200 A	EMDAG4282303T00010
	15/5.6	360 ... 848 VDC	15 kW/5.6 kW	24 VDC	1 x 15 A/200 A	1 x 27 A/200 A	EMDAG4562153C00010
	15/2.8	200 ... 848 VDC	15 kW/2.8 kW	12 VDC	1 x 15 A/200 A	1 x 27 A/200 A	EMDAG4282153T00010
PSU	5.6	360 ... 848 VDC	5.6 kW	24 VDC	-/200 A	-/200 A	EMDAG3562000C00010
	2.8	200 ... 848 VDC	2.8 kW	12 VDC	-/200 A	-/200 A	EMDAG3282000T00010

MOBILE DCU S



Housing platform

Type	Operating voltage	DCU/PSU current peak ¹	Secondary DC voltage	DCU/PSU output current nominal	DCU/PSU output current peak ²	Type number	
DCU S	22	200 ... 848 VDC	22 kW	-	22 A	-/ 38.7 A	EMDAG5223000U00000
	11	200 ... 848 VDC	11 kW	-	11 A	-/ 19.8 A	EMDAG5113000U00000

1 Inverter output with DC link voltage 800 VDC/motor voltage 560 VAC, DC/DC transformer output with DC output voltage 14/28 VDC
 2 peak current for 10 seconds

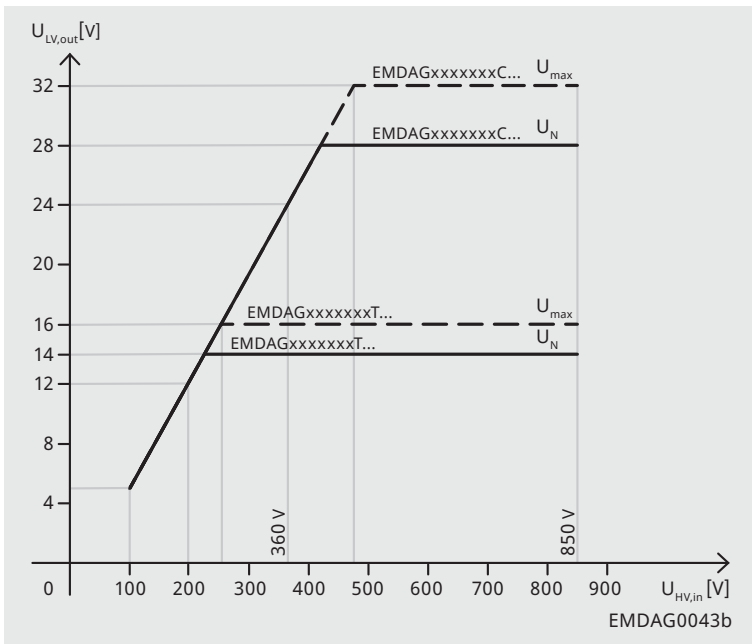

Diagram of the output voltage of the DC/DC converter
DC/DC converter: Output voltage with reference to the HV on-board voltage

$U_{HV,in}$ Voltage of HV on-board supply system
 $U_{LV,out}$ Output voltage of DC/DC converter
 U_N Rated output voltage
 U_{max} Max. rated voltage

Functions and features MOBILE Advanced (EMDA)

General		DCU		DCU S
Ambient temperature	-40°C ... +85°C	Continuous current DCU *7.5 / 15 / 30 / 60	*8 A / 15 A / 32 A / 58 A	11 A / 22 A
Cooling circuit	Water/glycol (50/50) 15 l/min, +30 °C ... +65 °C	Max. motor current	150% for 60s 180% for 10s	150% for 60s 180% for 10s
Connections	Plug screw terminals for DC/DC	Max. speed	20000 rpm	20000 rpm
Shock & vibrations	5.9 g	Max. output frequency	599 Hz	599 Hz
Protection against environmental influences	IP6K9K	Motor feedback (resolver/ temperature sensor)	2	Motor temperature sensor
Certification	ECE R10	HW interlock	X	X
Readable fault memory, cyclic error codes	X	Vector control and V/f control for asynchronous and synchronous motors with and without sensor	X	Only sensorless
CANopen	X	Precharge DC-link adjustable	Up to 848 V	Up to 848 V
Wake Over CAN	X			-
CANbus J1939	X	PSU		X
CANbus baud rate	125, 250, 500 kbps	Max. output current	Adjustable	
Digital outputs	DCU, DCU/PSU, PSU 4 DCU S 0	Parallel mode	8 devices	
Digital inputs/FlexINs	4	Continuous current PSU 2.8/5.6	200 A	
		Peak current PSU 2.8/5.6	200 A	
		Precharge DC-link adjustable	Up to 848 V	
Certification: ECE R10				
- Power socket function				
- Parameter set changeover via FlexINs or CAN message				
- Selection of up to 16 fixed speeds and torques via FlexINs				

Prefabricated Cables and Plug Accessories for MOBILE

Our pre-assembled cables for the motor connection and the connection to the HV on-board supply system ensure an optimum connection of the cable shield to the vehicle mass. This guarantees that an EMC-compliant installation is achieved. We recommend our cables for trouble-free operation of the MOBILE devices.

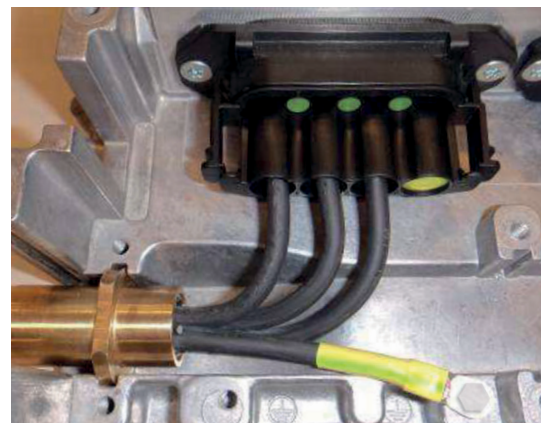

Function	Designation	Type	Application
HV on-board supply system	High voltage cable EMD X2, 2 × 4 mm ² , 10 m	EMDY906A0100K02A00	MOBILE DCU S
Motor	Motor cable EMD X3, 3 × 2.5 mm ² , 10 m	EMDY912A0100K03A00	MOBILE DCU S
HV on-board supply system	High voltage cable EMD X11, 2 × 10 mm ² , 10 m	EMDY904A0100E15A00	
	High voltage cable EMD X11, 2 × 6 mm ² , 10 m	EMDY905A0100E25A00	
	High voltage cable EMD X11, 2 × 4 mm ² , 10 m	EMDY906A0100E35A00	MOBILE DCU
	High voltage cable EMD X11, 4 × 10 mm ² , 10 m	EMDY900A0100E11A00	MOBILE PSU
	High voltage cable EMD X11, 4 × 6 mm ² , 10 m	EMDY901A0100E21A00	MOBILE DCU PSU
	High voltage cable EMD X11, 4 × 4 mm ² , 10 m	EMDY902A0100E31A00	
	High voltage cable EMD X11, 4 × 2.5 mm ² , 10 m	EMDY903A0100E41A00	
Motor	Motor cable EMD X12, 4 × 10 mm ² , 10 m, DCU	EMDY900A0100E12A00	MOBILE DCU
	Motor cable EMD X13, 4 × 10 mm ² , 10 m, DCU	EMDY900A0100E13A00	MOBILE DCU
	Motor cable EMD X13, 4 × 10 mm ² , 10 m, DCU PSU	EMDY900A0100E14A00	MOBILE DCU PSU
	Motor cable EMD X12, 4 × 6 mm ² , 10 m, DCU	EMDY901A0100E22A00	MOBILE DCU
	Motor cable EMD X13, 4 × 6 mm ² , 10 m, DCU	EMDY901A0100E23A00	MOBILE DCU
	Motor cable EMD X13, 4 × 6 mm ² , 10 m, DCU PSU	EMDY901A0100E24A00	MOBILE DCU PSU
	Motor cable EMD X12, 4 × 4 mm ² , 10 m, DCU	EMDY902A0100E32A00	MOBILE DCU
	Motor cable EMD X13, 4 × 4 mm ² , 10 m, DCU	EMDY902A0100E33A00	MOBILE DCU
	Motor cable EMD X13, 4 × 4 mm ² , 10 m, DCU PSU	EMDY902A0100E34A00	MOBILE DCU PSU
	Motor cable EMD X12, 4 × 2.5 mm ² , 10 m, DCU	EMDY903A0100E42A00	MOBILE DCU
	Motor cable EMD X13, 4 × 2.5 mm ² , 10 m, DCU	EMDY903A0100E43A00	MOBILE DCU
	Motor cable EMD X13, 4 × 2.5 mm ² , 10 m, DCU PSU	EMDY903A0100E44A00	MOBILE DCU PSU

Finished HV cables

MOBILE system cable	Cross-section	Length	Application slot	Application slot	Application slot	Application slot	Cable end
		Your desired length	MOBILE DCU MOBILE PSU MOBILE DCU PSU	MOBILE DCU	MOBILE DCU	MOBILE DCU PSU	Cable cut to length
EMDY	900 (10 mm ²)	A0100	E11 = X11	E12 = X12	E13 = X13	E14 = X13	A00
EMDY	901 (6 mm ²)		E21 = X11	E22 = X12	E23 = X13	E24 = X13	A00
EMDY	902 (4 mm ²)		E31 = X11	E32 = X12	E33 = X13	E34 = X13	A00
EMDY	903 (2.5 mm ²)		E41 = X11	E42 = X12	E43 = X13	E44 = X13	A00

Exclusively for series requirements, we can also offer you finished HV cables accurate up to 0.1 m in the length and cross-section you desire. Our type code is structured as follows: e.g., High voltage cable

4 × 10 mm², 10 m, X11 = EMDY900A0100E11A00



Control plug

X31



HV plug

X11, X12, X13

Function	Designation	Type	Application
HV plug	Plug kit for X11/X12/X13 including housing, crimp contacts, seals	EZAEVE027	MOBILE DCU MOBILE PSU MOBILE DCU PSU
Control plug	Plug EMD accessory kit 26 pole cpl. for X31	EZAEVE028	MOBILE DCU MOBILE PSU MOBILE DCU PSU
Resolver	Resolver cable Mobile X32, X33, 1.5 m	EMDY700F0015B03A01	
	Resolver cable Mobile X32, X33, 3.0 m	EMDY700F0030B03A01	
	Resolver cable Mobile X32, X33, 5.0 m	EMDY700F0050B03A01	MOBILE DCU
	Resolver cable Mobile X32, X33, 10 m	EMDY700F0100B03A01	MOBILE DCU PSU
Operation without drive	Power connector cover for X12, X13	EZAMSK002	
MOBILE Engineer	Single user license supplied on USB dongle	EMDABUS01	

bucherdrives.com

Bucher Hydraulics AG
Mobile Drives
Obere Neustrasse 1
8590 Romanshorn
Switzerland
+41 41 757 03 33
info.ch@bucherdrives.com

Sales and Support
sales.ch@bucherdrives.com

Claims and Returns
Bucher Automation AG
Thomas-Alva-Edison-Ring 10
71672 Marbach a.N
Germany

Request ticket number
before returning at:
claims.ch@bucherdrives.com

**Smart Solutions.
Superior Support.[®]**